

Simply a question of better measurement



SCHMIDT® Flow Sensor SS 23.700 Ex

A robust flow sensor for highly demanding heavy-duty applications in air and other gases and explosive atmosphere

- Sensor elements completely encapsulated in stainless steel
- Wide flow measuring range from 0.1 to 220 m/s
- Temperature measuring range from -20 to +120 °C
- For air and other gases in applications with harsh conditions (medium with aggressive components, contamination, high humidity)
- ATEX version (zone 2/gas and zone 22/dust)
- PWIS-conform (order option)
- Very robust design and overpressure resistant up to 16 bar
- Easy cleaning due to encapsulated stainless steel surface
- Sensor configuration by module interface

Heavy-Duty applications

Industrial processes

Compressed air technology

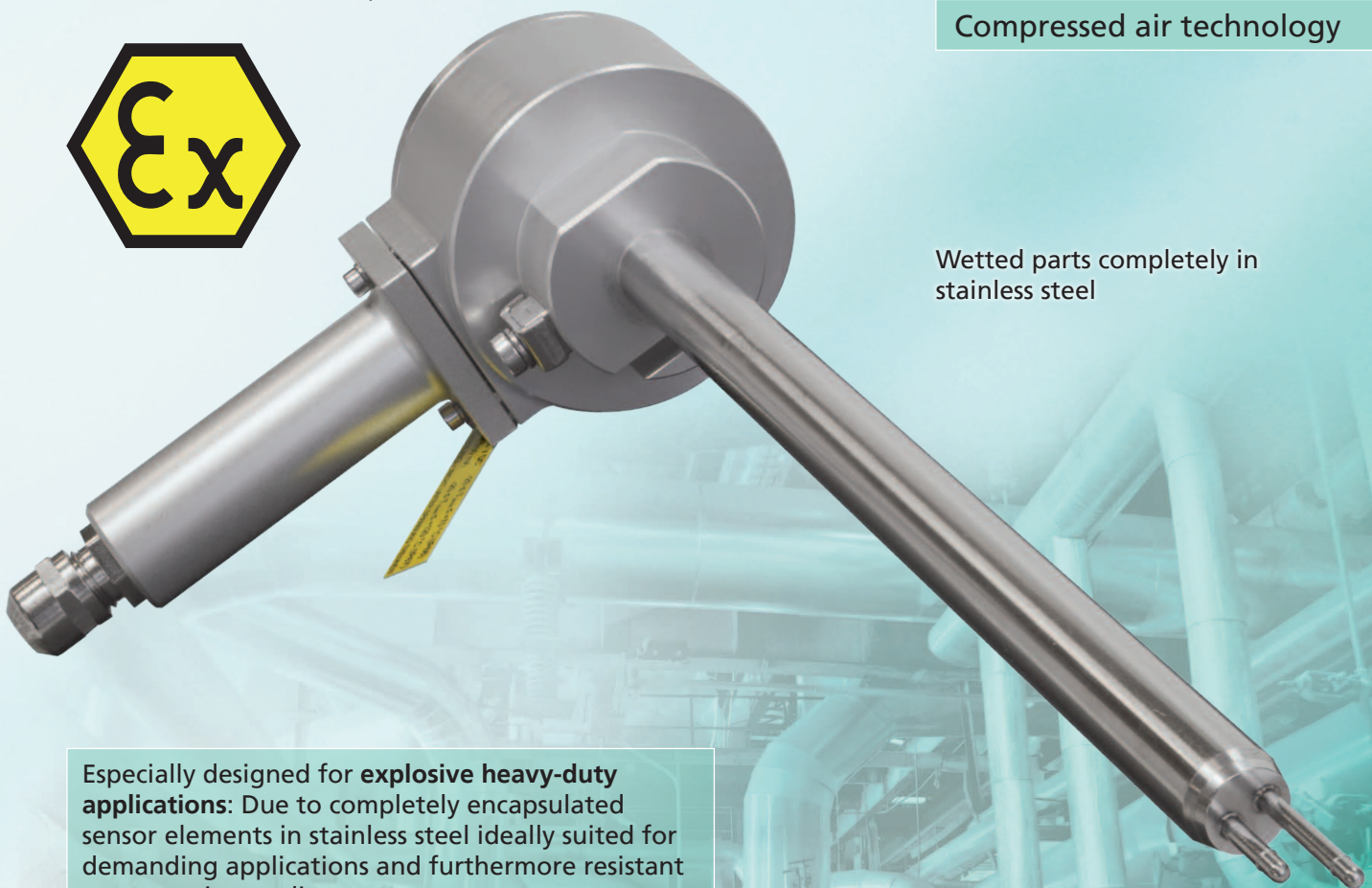

Wetted parts completely in stainless steel

Especially designed for **explosive heavy-duty applications**: Due to completely encapsulated sensor elements in stainless steel ideally suited for demanding applications and furthermore resistant to aggressive media.



Flow rate volumes of gases – an important parameter in industrial processes

Actions to save energy and to assure quality in the production process are of particular importance in industrial processes. The ability to measure volumetric flow rates and volumetric flow of gases precisely is essential for this purpose. The requirements imposed on the flow rate sensor used for this are demanding: the sensor has to be capable of delivering precise measuring results for different gases, at high overpressures and across wide ranges of temperature. It also has to be able to do so under the most difficult environmental conditions. A further decision factor is the prevention of maintenance and its attendant high secondary costs. Simple assembly and reliable measuring values for many years are expected.

The “true professional” for industrial processes and compressed air technology

The thermal SCHMIDT® Flow Sensor SS 23.700 Ex is the perfect solution for extremely demanding industrial applications. It can be used for a diverse range of applications, such as compressed air monitoring, gas monitoring on process burners, consumption recording of gases and a great deal more.

The double-pin sensor head has been designed to meet the needs of so-called „heavy-duty applications“ and, due to the sensor elements being completely encapsulated in stainless steel these are ideally suited for extremely demanding applications such as the generation of biogas and for use in both zone 2 explosive gas atmospheres and zone 22 explosive dust atmospheres. The sensor is also resistant against aggressive media.

The SS 23.700 Ex records flow speed as well as media temperatures up to 120 °C. It can be used in small tubes starting from DN 40 upwards and involve a sensor length up to 600 mm to measure the volumetric flow rate in large channels and ducts. The sensor can be used in overpressure up to 16 bar.

This sensor is very easy to install: screw in the sensor using the compression fitting included, align the sensor in the gas flow and centrally in the pipe, connect it electrically – ready!

This sensor operates without any moving parts and employs a measuring principle that eliminates any drift or signs of ageing. This reduces the maintenance required for the sensor to an absolute minimum. Should cleaning nevertheless be necessary, it can be carried out very easily and in a variety of ways – simply the spirit of „heavy-duty“.

High gas speeds or combustible gases? The SS 23.700 Ex can do both!

The sensor with its special double-pin sensor head records flow speeds of 0.1 m/s up to 220 m/s. In order to obtain precise measuring results across this very broad speed range, every sensor is individually adjusted and calibrated in an elaborate pressurized wind tunnel.

To enable this sensor to be used in different gases, a range of individual versions are available, e.g. for methane, biogas, natural gas, COs, argon and more.

How does it work?

The two sensor elements for measuring flow and medium temperature are positioned in two separate stainless steel sleeves and perfectly protected from harmful influences by the encapsulation. The flow sensor is heated to a defined temperature above the temperature of the medium. The power required to maintain this positive temperature differential (“overtemperature”) is an indicator for the flow rate speed that the sensor issues as “normal speed” (linear current / voltage / impulse signal). This is a great advantage of the measuring principle: No additional measurement of the pressure or temperature of the medium are required.

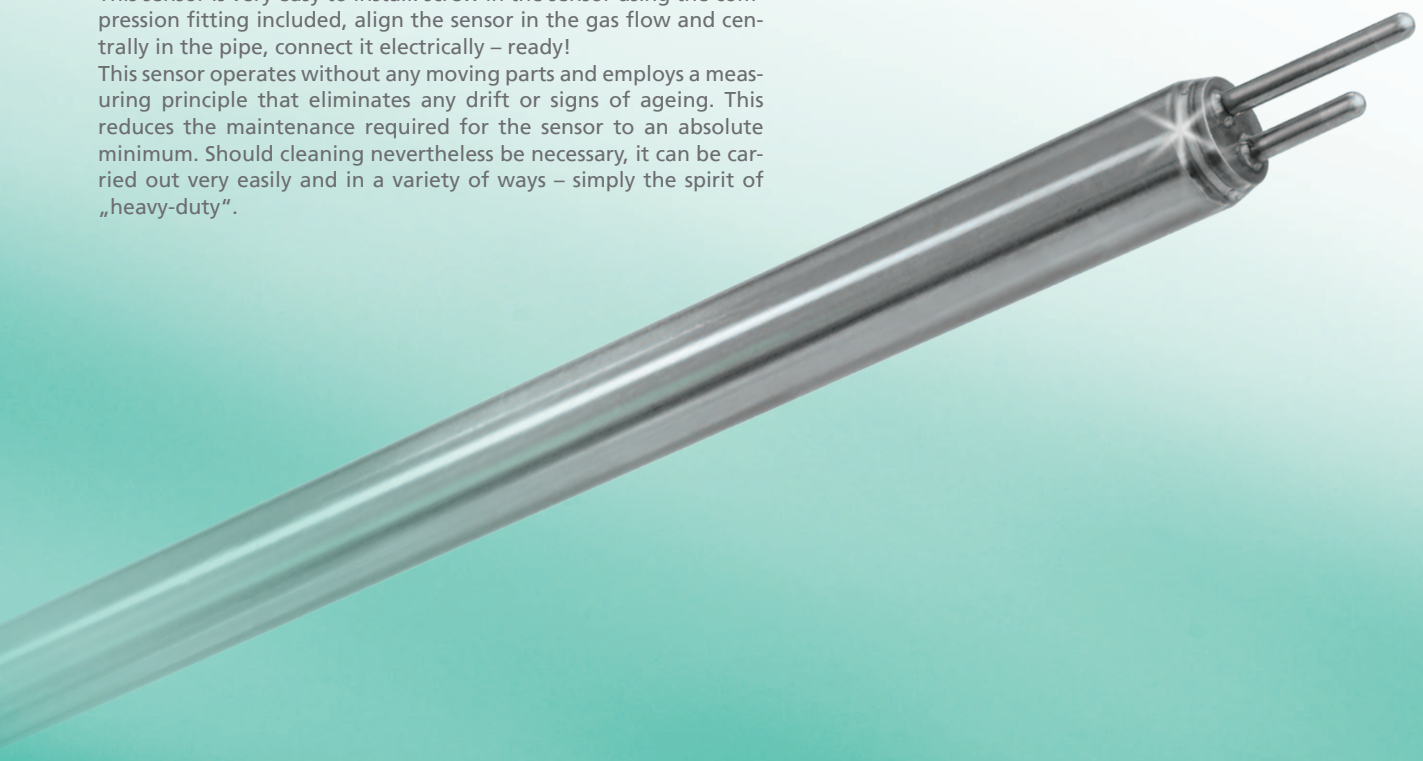

Individually adapted to suit every application

For optimum installation in the various different pipe diameters, 2 standard sensor lengths can be selected. A remote version is available for difficult installation conditions. Cable length between sensor and housing (max. 10 m) can be defined by the customer.

To enable the sensor to be adapted to flow rate conditions, different standard measuring ranges are available, extending up to 220 m/s. The volumetric flow rate is the result of the flow rate speed, multiplied by the pipe cross-sectional surface area and a profile factor. However, customer-specific measuring ranges can also be supplied in increments of 1 m/s. The advantage of this is that a desired maximum volumetric flow rate determines the measuring range of the sensor depending on pipe diameter. Example: Maximum volumetric flow rate of 450 m³/h with a pipe diameter of DN 65 yields a maximum flow rate measuring range for the sensor of approx. 48 m/s (= 20 mA or 10 V). For the purposes of simple conversion, the homepage features a flow rate calculator that also determines the profile factor, which is dependent on the pipe cross section. For evaluation systems with impulse inputs, the SS 23.700 Ex offers an additional impulse output for the flow rate signal. There is a standard measuring range of 0...100 Hz available or, if the pipe diameter is indicated, impulses per m³ as a customer-specific output as an option.

Measure other gas media, too? Absolutely!

Often the measurement medium is not air, but consists of other gases or gas mixtures. For these special applications, gas-specific versions of the SS 23.700 Ex can be supplied.

With these versions, the sensor has a specific correction – based on adjustment in air – programmed. These correction factors were established individually for each gas on real gas channels. For gas mixtures, each correction is calculated on the basis of an individual customer specification. In some applications (e. g. in painting processes), greases and “paint-wetting impairment substances” (PWIS) must be strictly avoided. For such applications, a special order option “PWIS-conform” is available and offers the necessary safety in these applications as well.

Accuracy – in black & white

The SS 23.700 Ex is adjusted to air in a highly accurate reference wind tunnel. The subsequent calibration is also valid for pure oxygen and nitrogen. The high accuracy and reproducibility is documented in a factory calibration certificate (order option). This calibration can be renewed as specified by the user.

All at a glance!

The LED display is used for function monitoring and quick error analysis on site. The SS 23.700 Ex has four LEDs embedded in the cover, which indicate the current flow range and can also signal an error code in the event of a fault.

Use in combustible or explosive gases

The SS 23.700 Ex is designed for use in both zone 2 explosive gas atmospheres and zone 22 explosive dust atmospheres. For this, specific protection functions are incorporated, among other things, one example being a protective sleeve for the plug connector and the ground / earth terminal on the enclosure or, on the remote version, with an additional one on the sensor tube. The SS 23.700 Ex enables a minimum gas temperature of -20 °C to be reached.

Connect and you are ready

Flexible connection of the analogue outputs is possible due to automatic V or mA switching depending on the connected load (Auto-U/I).





Accessories

SCHMIDT® Probe ball valve

A choice of probe ball valves are available to facilitate fast removal and installation in 1" to 2" pipework. Advantage: Even while the system is under pressure, it is no problem to install or remove the sensor. A straight-run ball valve is available for larger pipework diameters.



LED measured value display

For visualization purposes directly on site, an LED unit is available to display measuring values. The advantages:

- Display in m/s or m³/h
- Programmable output signal
- Two programmable relay outputs
- Power supply: 85 – 250 V AC or 24 V DC
- Power supply to the connected sensor
- Separate version with "summing" function



Connection cable available in various lengths



Welding steel sleeves or stainless steel

Dimensions of the basic sensor

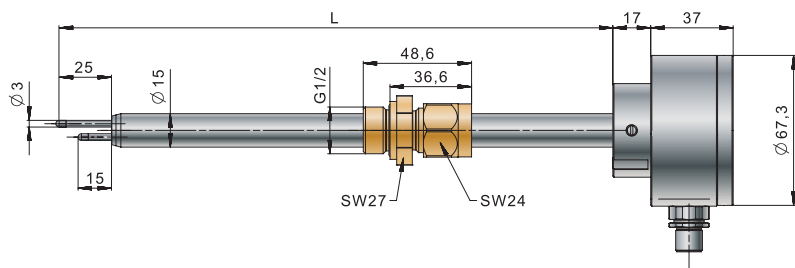

Remote sensor (including wall-mounting bracket)

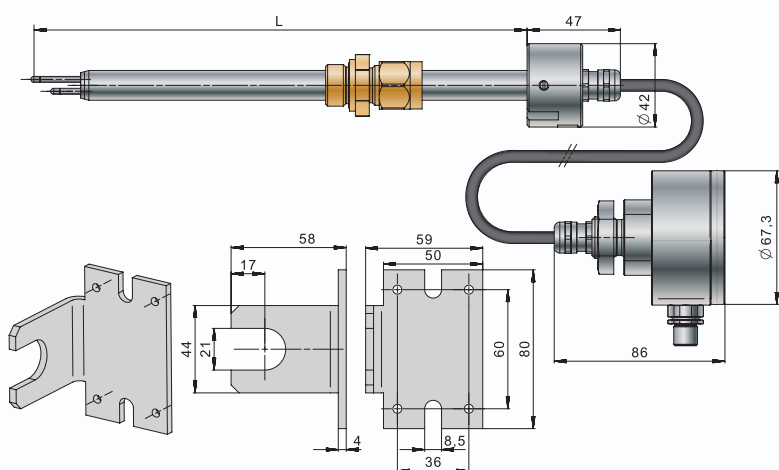

Mounting instructions

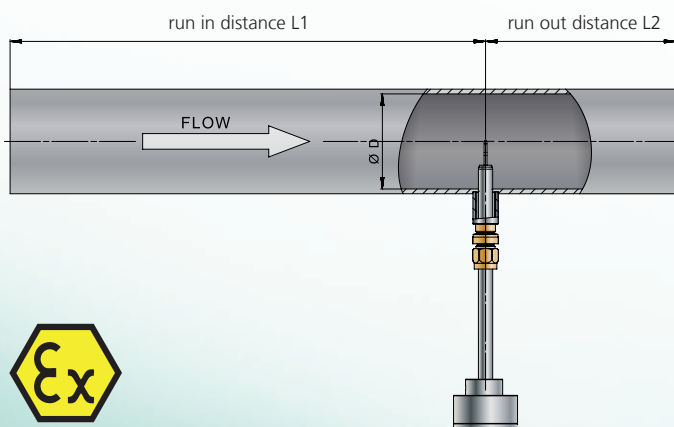

Mounting parameters

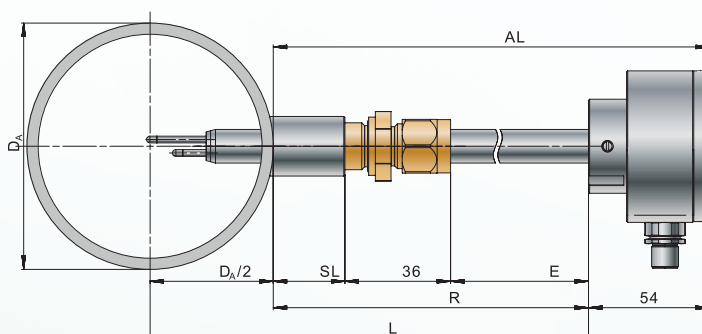

- D_A = Outer diameter of tube
- SL = Length of welding sleeve
- E = Adjustable length of sensor tube
- AL = Extended length of compact sensor
- R = Reference length
- L = Length of sensor
- All dimensions in mm

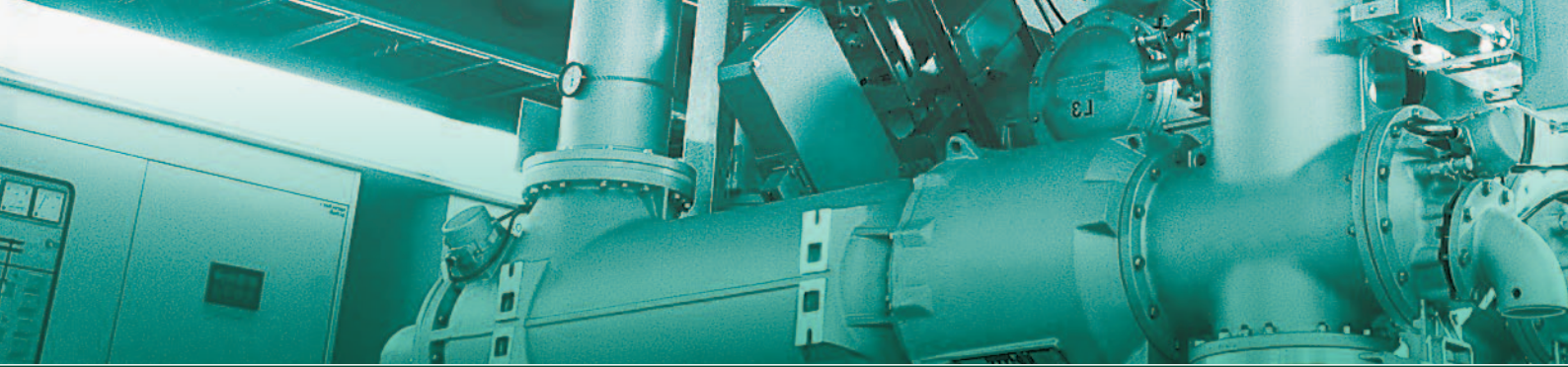

Technical Data

Measurement-specific data	
Measuring values	Standard velocity w_N of air, based on standard conditions of 20 °C and 1,013.25 hPa Temperature of medium T_M
Medium to be measured	Standard: air or nitrogen Optional: biogas, methane, natural gas, argon, COs, special gases and mixtures and others (on request)
Measuring range w_N	Standard: 0 ... 10 / 20 / 60 / 90 / 140 / 220 m/s Special: 10 ... 220 m/s (steps: 1 m/s)
Lower detection limit w_N	0.1 m/s
Measuring range T_M	-20 ... +120 °C
Measuring accuracy ¹⁾	
Standard w_N	$\pm(3\%$ of measured value + $[0.4\%$ of fmr; min. 0.08 m/s]) ²⁾
Response time (t_{90}) w_N	10 s (jump of w_N from 0 to 5 m/s in air)
Measuring accuracy T_M ($w_N > 5$ m/s)	± 1 K ($T_M = 10 \dots 30$ °C) ± 2 K remaining measuring range
Operating temperature	
Sensor probe	-20 ... +120 °C
Electronics	-20 ... +70 °C
Storage temperature	-20 ... +85 °C
Material	
Housing	Anodized aluminium
Sensor tube	Stainless steel 1.4571
Compression fitting	Stainless steel 1.4571, FKM (depending on version)
Sensor head	Stainless steel 1.4404
Sensor cable (remote sensor)	Sheathing TPE, halogen-free
General data	
Humidity range	Measuring mode: non-condensing (< 95 % RH)
Operating overpressure (max.)	16 bar
Display	Stripe of 4 dual LEDs (green / red / orange)
Supply voltage U_b	24 V DC ± 20 %
Current consumption	Approx. 80 mA (without pulse outputs); max. 250 mA ³⁾
Analog outputs - Type: Auto U / I Switching Auto-U/I - Voltage output - Current output	Flow velocity, temperature of medium Automatic switching signal mode based on load R_L 0 ... 10 V for $R_L \geq 550 \Omega$ 4 ... 20 mA for $R_L \leq 500 \Omega$
Pulse outputs - Signalling: - Pulse output 1: - Pulse output 2:	0 ... 100 Hz; Option: 1 pulse / 1 m ³ 1 pulse / 0.1 m ³ 1 pulse / 0.01 m ³ (max. 100 Hz) High-side driver connected to U_b (without galvanic separation) Semiconductor relay (output galvanically separated) max. 30 V _{DC} / 21 V _{AC,eff} / 50 mA
Electrical connection	M12, male, A-coded, 8-pin
Maximum cable length	Voltage signal: 15 m, current signal / pulse: 100 m
Installation position (relative to g-vector)	Arbitrary (exception: Temperature element may never be placed "above" heater element)
Direction / mounting tolerance	Unidirectional / $\pm 3^\circ$ relative to flow direction
Minimum immersion depth	DN 40
Type of protection	IP66 (housing), IP67 (sensor probe)
Protection class	PELV (according EN 50178)
ATEX category	II 3G Ex ec ic IIC T4 Gc II 3D Ex ic tc IIIC 135°C Dc
Probe length - Compact sensor - Remote sensor	Standard: 250 / 600 mm Probe: 250 / 600 mm Cable: 1 ... 10 m (steps: 1 m)
Weight	Approx. 500 g max. (without connecting cable)

¹⁾ Under reference conditions

²⁾ fmr = final measuring range

³⁾ Without signal current of pulse output 2 (relay)

Order information SCHMIDT® Flow Sensor SS 23.700 Ex

	Description	Article Number								
		A	B	C	D	E	F	G	DD	
Basic sensor	SCHMIDT® Flow Sensor SS 23.700 Ex; Basic version: w _N & T _M ; 16 bar Output signal: Auto U/I; incl. compression fitting and pressure protection kit									
		569700-								
	Options									
Type	Standard		1							
Mechanical type	Sensor length 250 mm			1						
	Sensor length 600 mm			2						
	Remote version (selectable sensor length: (250 / 600 mm); cable length: 1 ... 10 m; 1 m-steps			9						
	Pressure-tight compression fitting stainless steel G ½				1					
	Pressure-tight compression fitting stainless steel R ½ (PT)				2					
Measuring ranges and adjustment ¹⁾	Measuring range 0 ... 10 m/s					1				
	Measuring range 0 ... 20 m/s					2				
	Measuring range 0 ... 60 m/s					3				
	Measuring range 0 ... 90 m/s					4				
	Measuring range 0 ... 140 m/s					5				
	Measuring range 0 ... 220 m/s					6				
	Special measuring range: 10 m/s ... 220 m/s; 1 m/s steps					9				
	Standard adjustment							1		
	Standard adjustment with factory calibration certificate							2		
	Standard adjustment w/ correct. methane							3		
	Standard adjustment w/ correct. biogas (60 % methane, 40 % CO ₂)							4		
	Standard adjustment w/ correct. factor for CO ₂							5		
	Standard adjustment w/ correct. natural gas (88 % CH ₄)							7		
	Standard adjustment w/ correct. argon							8		
Standard adjustment w/ correct. special gases and mixtures							9			
Impulse output	Standard 100 Hz (= measuring end value w _N)							1		
	1 Impulse / 1 m ³ for tube Ø (round) ____ mm							2		
	1 Impulse / 0.1 m ³ for tube Ø (round) ____ mm							3		
	1 Impulse / 0.01 m ³ for tube Ø (round) ____ mm							4		
Scope of application	Standard								1	
	PWIS-conform (paint-wetting impairment substances), with pressure tight compression fitting stainless steel G ½ with cutting sealing (only for C = 1)								3	
Overpressure	DD: 00 (atmospheric) ... 16 bar overpressure									00 ... 16

¹⁾ To select the appropriate measurement range, please use our flow calculator tool on www.schmidttechnology.de.
Other gases on request.

Order information SCHMIDT® Flow Sensor SS 23.700 Ex

	Description	Article number
Accessories	Connecting cable, 8 pole, length 5 m, with coupler socket and open cable end	524 921
	Connecting cable, 8 pole, length selectable, with cable end sleeves, free of halogen	524 942
	Welding sleeve steel G ½ acc. to EN 10241, 5 pieces	524 916
	Welding sleeve stainless steel 1.4571 G ½ acc. to EN 10241, 2 pieces	524 882
	Power supply: output 24 V DC / 1A; input 115 / 230 V AC	535 282
	SCHMIDT® LED display MD 10.010; in wall housing to show the volume flow and flow velocity, 85 ... 230 V AC and sensor supply	527 320
	SCHMIDT® LED display MD 10.010; similar to 527 320, but with 24 V DC voltage supply	528 240
	SCHMIDT® LED display MD 10.015; in wall-mounted housing, similar to 527 320 but with additional sum function and second measuring input	527 330
	SCHMIDT® LED display MD 10.015; similar to 527 330, but with 24 V DC voltage supply	528 250
	Assembly kit for pipe assembly, suitable for MD 10.010 / 10.015, including pipe clamps and collar for adjustment to the pipe diameter	531 394
	Probe ball valve 1" inside thread, connection to flow sensor: ½" inside thread incl. plug and chain	530 940
	Probe ball valve 1¼" inside thread, connection to flow sensor: ½" inside thread incl. plug and chain	530 941
	Probe ball valve 1½" inside thread, connection to flow sensor: ½" inside thread incl. plug and chain	530 942
	Probe ball valve 2" inside thread, connection to flow sensor: ½" inside thread incl. plug and chain	530 943
	Straight-run probe ball valve ¾" inside thread, with threaded adapter for ½" full-length screw connection ¾"	532 355
	Welded socket, steel, outside thread ¾", 5 pieces	531 200
	Welded socket, stainless steel, outside thread ¾", 2 pieces	531 201

SCHMIDT Technology GmbH

Feldbergstrasse 1
78112 St. Georgen/Germany

Telefon +49 (0) 77 24/8990

sensors@schmidttechnology.de
www.schmidttechnology.de
www.schmidt-sensors.com